

No Free Lunch: 1995-2008

Darrell Whitley
Colorado State University

Copyright is held by the author. GECCO08, July 12-16, 2008, Atlanta,
Georgia, USA. ACM 978-1-60558-130-9/08/07.

GECCO-2008 -1

NFL: No Free Lunch

*All search algorithms are equivalent when compared
over all possible discrete functions.*

Wolpert, Macready (1995)

No free lunch theorems for search. Santa Fe Institute.

Radcliffe, Surry (1995)

Fundamental Limitations on Search Algorithms: Springer Verlag LNCS 1000.

No Free Lunch for Gray and Binary

*All search algorithms are equivalent when compared
over all possible representations.*

Variations on No Free Lunch

For ANY measure of algorithm performance:

The aggregate behavior of any two search algorithms is equivalent when compared all possible discrete functions.

The aggregate behavior of ALL possible search algorithms is equivalent when compared over any two discrete functions.

At each distinct “iteration” of search the aggregate behavior of all possible search algorithms is IDENTICAL at each and every iteration.

GECCO-2008 -3

Variations on No Free Lunch

Consider any algorithm A_i applied to function f_j .

$On(A_i, f_j)$ outputs the order in which A_i visits the elements in the codomain of f_j . For every pair of algorithms A_k and A_i and for any function f_j , there exist a function f_l such that

$$On(A_i, f_j) \equiv On(A_k, f_l)$$

Consider a “BestFirst” local search with restarts.

Consider a “WorstFirst” local search with restarts.

For every j there exists an l such that

$$On(BestFirst, f_j) \equiv On(WorstFirst, f_l)$$

GECCO-2008 -4

GECCO 2008 Tutorial / No Free Lunch

ENUMERATION is a search algorithm.

Thus, No Free Lunch implies that on average,
no search algorithm is better than enumeration.

Furthermore, because bias in search algorithms causes them to focus the
search, most are prone to resampling.

If resampling is considered,
“focused” search algorithms are WORSE than enumeration

NFL IGNORES RESAMPLING

GECCO-2008 -5

An algorithm is modeled as a permutation
representing the order in which new points are tested.

Behavior is defined in terms of the evaluation function output
which defines the co-domain of the function.

GECCO-2008 -6

GECCO 2008 Tutorial / No Free Lunch

Assume that one is given a fixed set of co-domain values.

Set of Functions = Set of Permutations.

BEHAVIORS	FUNCTIONS
A1: 1 2 3	F1: A B C
A2: 1 3 2	F2: A C B
A3: 2 1 3	F3: B A C
A4: 2 3 1	F4: B C A
A5: 3 1 2	F5: C A B
A6: 3 2 1	F6: C B A

GECCO-2008-7

Assume $(A > B) \& (B > C)$.

Take 2 steps, return the maximum found.

	F1	F2	F3	F4	F5	F6
A1	A	A	A	B	A	B
A2	A	A	B	A	B	A
A3	A	A	A	B	A	B
A4	B	B	A	A	A	A
A5	A	A	B	A	B	A
A6	B	B	A	A	A	A

GECCO-2008-8

GECCO 2008 Tutorial / No Free Lunch

NFL is just like sampling
from a grab bag.

Co-Domain: 1 2 3 4 5 6

Values sampled so far:
3 6 1

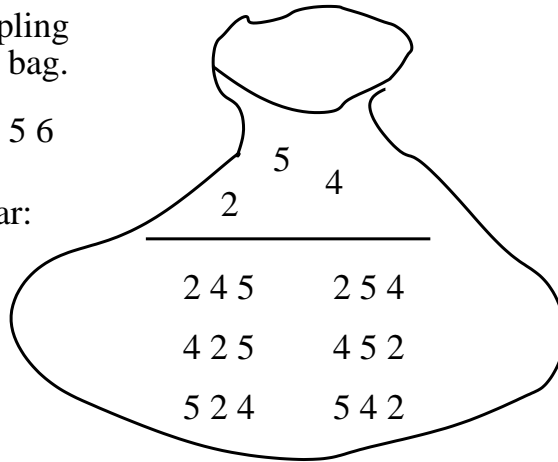

GECCO-2008 -9

Theorem:

NFL holds for a set of functions IFF
the set of functions form a permutation set.

The “Permutation Set” is the closure of a set
of functions with respect to a permutation operator.
(Schmacher, Vose and Whitley-GECCO 2001).

F1: 0 0 1 2	F7: 0 2 0 1
F2: 0 1 0 2	F8: 0 2 1 0
F3: 1 0 0 2	F9: 1 2 0 0
F4: 0 0 2 1	F10: 2 0 0 1
F5: 0 1 2 0	F11: 2 0 1 0
F6: 1 0 2 0	F12: 2 1 0 0

GECCO-2008 -10

Machine Learning and NFL

1	1	1	1
1			1
0			0
0	0	0	0

L1	ALL	HD	L2	ALL	HD
==	=====		==	=====	
	00	0		00	1
00	01	1	10	01	2
	10	1		10	0
	11	2		11	1

GECCO-2008 -11

Theorem:

Given a finite set of N unique co-domain values, NFL hold over a set of $N!$ functions where the average description length is $O(N \log N)$.

Sketch of Proof:

Construction a Binary Tree with $N!$ leaves. Each leaf represents one of the $N!$ functions. To just label each function requires $\log(N!)$ bits. Each label has average length $\log(N!) = O(N \log N)$.

Note enumeration also has cost $O(N \log N)$.

Corollary:

If a fixed fraction of the co-domain values are unique, the set of $N!$ functions where NFL holds has average description length $O(N \log N)$.

GECCO 2008 Tutorial / No Free Lunch

NFL holds over sets with 1 member.

$$F = 0 \ 0 \ 0 \ 0$$

NFL holds over needle-in-a-haystack functions.

$$F1 = 0 \ 0 \ 0 \ 1$$

$$F2 = 0 \ 0 \ 1 \ 0$$

$$F3 = 0 \ 1 \ 0 \ 0$$

$$F4 = 1 \ 0 \ 0 \ 0$$

GECCO-2008-13

The set of Binary strings is a permutation set

0 0 0 0

1 1 1 1

0 0 0 1

0 0 1 1

1 1 1 0

0 0 1 0

0 1 0 1

1 1 0 1

0 1 0 0

1 0 0 1

1 0 1 1

1 0 0 0

0 1 1 0

0 1 1 1

1 0 1 0

1 1 0 0

GECCO-2008-14

Let $P(F)$ compute the permutation closure of F , where F is a set of functions.

Let $K = |P(F)|$.

Then the average description length needed to distinguish the members of that set is $lg(K)$.

If $lg(K)$ is exponential, then the permutation set is *uncompressible*.

If $lg(K)$ is polynomial, then the permutation set is *compressible*.

GECCO-2008 –15

QUESTION:

How should we evaluate search algorithms?

Let β represent a set of benchmarks. $P(\beta)$ is the permutation closure over β .

*If algorithm **S** is better than algorithm **T** on β
THEN **T** is better than **S** on $P(\beta) - \beta$.*

GECCO-2008 –16

GECCO 2008 Tutorial / No Free Lunch

		Algorithm 1	Algorithm 2
Set A	F1:	1 2 3 f(1) --> 1	f(3) --> 3
	F2:	1 3 2 f(1) --> 1	f(3) --> 2
Set B	F3:	2 1 3 f(1) --> 2	f(3) --> 3
	F4:	2 3 1 f(1) --> 2	f(3) --> 1
	F5:	3 1 2 f(1) --> 3	f(3) --> 2
	F6:	3 2 1 f(1) --> 3	f(3) --> 1

	Algorithm 1	Algorithm 2	Difference
Set A	2	5	3
Set B	10	7	3

The cumulative difference must be the same

GECCO-2008 -17

		Algorithm 1	Algorithm 2
Set A	F1:	1 2 3 f(1) --> 1	f(3) --> 3
	F2:	1 3 2 f(1) --> 1	f(3) --> 2
Set B	F3:	2 1 3 f(1) --> 2	f(3) --> 3
	F4:	2 3 1 f(1) --> 2	f(3) --> 1
	F5:	3 1 2 f(1) --> 3	f(3) --> 2
	F6:	3 2 1 f(1) --> 3	f(3) --> 1

	Algorithm 1	Algorithm 2	Difference
Set A	1	2.5	1.5
Set B	2.5	1.75	0.75

Average difference is not the same

GECCO-2008 -18

NO FREE LUNCH does not hold over the class of problems in NP; they are not black box optimization problems.

For example, some problems in NP that have ratio bounds which can be exploited by branch and bound algorithms.

Even, so claims about which algorithms apply to which problems is a concern.

GECCO-2008 –19

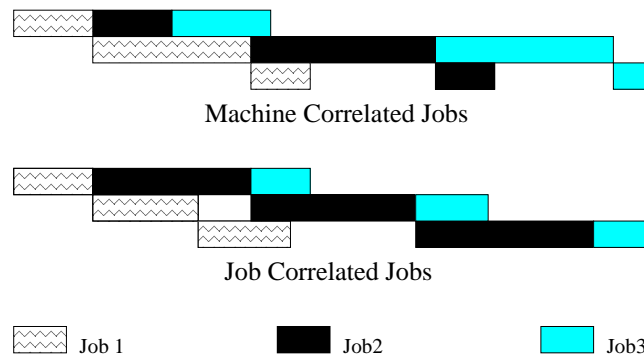

The PERMUTATION FLOWSHOP SCHEDULING PROBLEM.

Benchmark are typically generated randomly. Real-world problems may have correlated structure. Job could be *machine correlated* or *job correlated*.

GECCO-2008 –20

GECCO 2008 Tutorial / No Free Lunch

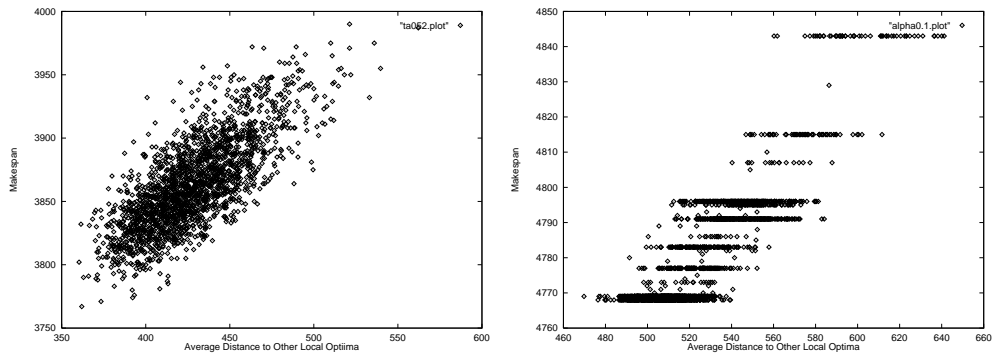

GECCO-2008 -21

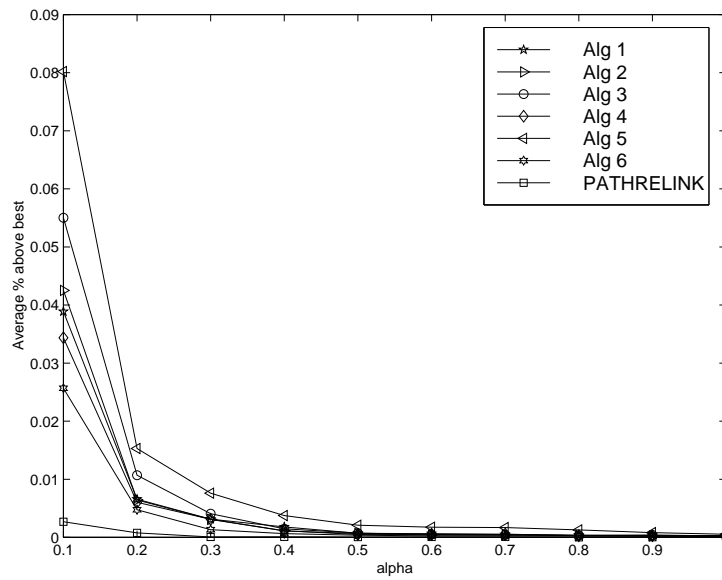

JOB CORRELATED PROBLEMS. Performance of optimization algorithms. The degree of randomness is indicated along the x-axis, while the deviation from the best-known solution is indicated along the y-axis.

GECCO-2008 -22

GECCO 2008 Tutorial / No Free Lunch

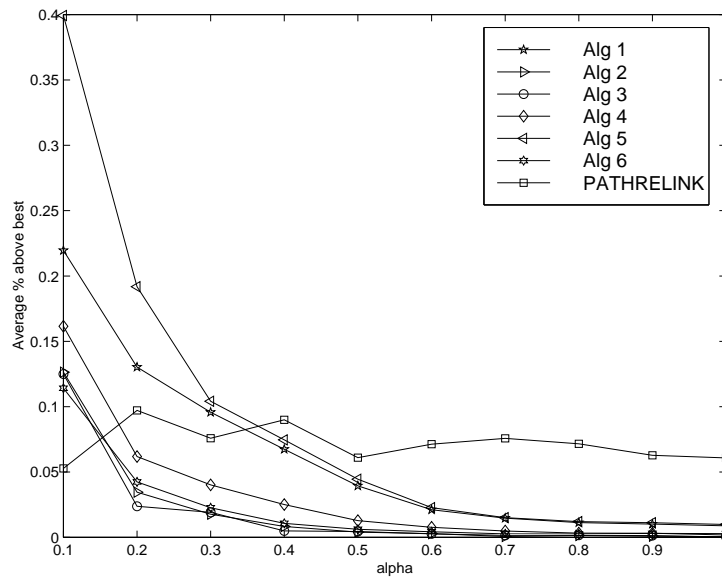

MACHINE CORRELATED PROBLEMS. Performance of optimization algorithms. The degree of randomness is indicated along the x-axis, while the deviation from the best-known solution is indicated along the y-axis.

GECCO-2008 –23

S. Christensen and F. Oppacher

What can we learn from No Free Lunch? GECCO 2001

A SUBMEDIAN-SEEKER Type Algorithm

1. Evaluate a sample of points and estimate $median(f)$.
2. If $f(x_i) < median(f)$ then sample a neighbor of x_i .
Else sample a new random point.
3. Repeat step 2 until half of space is explored.

Assume f is 1-dimensional, a bijection, and we know $median(f)$.

GECCO-2008 –24

2600

Let $M(f)$ measures the number of submedian values of f that have *supermedian successors*.

There exists M_{crit} such that when $M(f) < M_{crit}$ SubMedian-Seeker is better than random search.

SUBMEDIAN-SEEKER beats random enumeration when:

1. f is a uniformly sample polynomial of degree at most k and $M_{crit} > k/2$
2. f is a truncated Fourier series of at most k harmonics uniformly sampled over $[0,1)$ at n locations and $M_{crit} > k/2$
3. Each extremum of f is represented by at least 6 points on average

GECCO-2008 -25

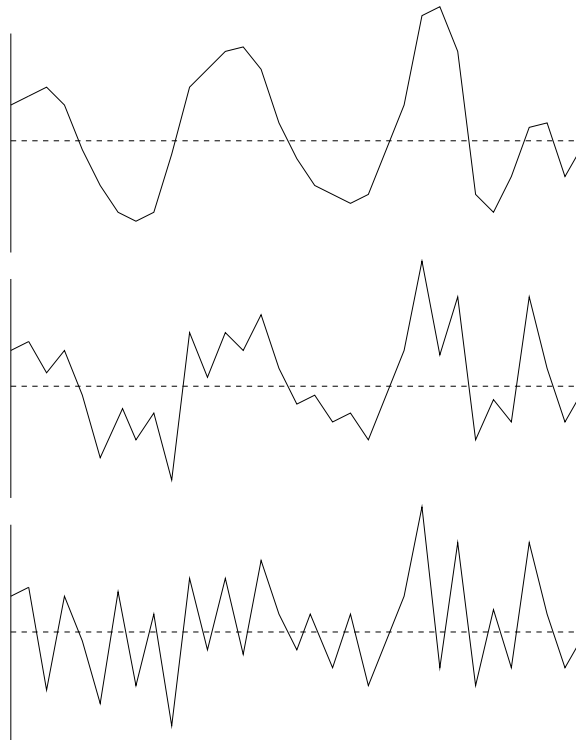

GECCO-2008 -26

Structure is Important

Random Number Generators produce functions that are in some restricted sense compressible. But they are designed to have minimal structure.

Consider “WorstFirst” local search again.

For every j there exists an l such that

$$On(BestFirst, f_j) \equiv On(WorstFirst, f_l)$$

There are “structured functions” that do not fit our usual notion of being “searchable.”

GECCO-2008 –27

NO FREE LUNCH and REPRESENTATION

Radcliffe, Surry (1995) Fundamental Limitations on Search Algorithms:
Springer Verlag LNCS 1000.

The behavior of any two algorithms are identical over all possible representations of a single function.

”NO-FREE-LUNCH-like” results

The behavior of any two algorithms are identical over over the set of Gray and the set of Binary representations over all possible functions.

GECCO-2008 –28

Counting Local Optima

The probability that string i is a local minimum under an arbitrary transformation of a k -neighborhood search space is:

$$P(i) = \frac{\binom{N-i}{k}}{\binom{N-1}{k}} \quad [1 \leq i \leq (N - k)] \quad (1)$$

GECCO-2008 -29

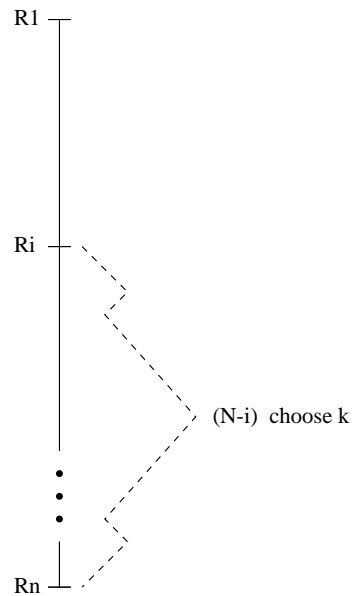

GECCO-2008 -30

The average number of local optima over all possible representations using a k-neighbor search:

$$\mu(N, k) = \sum_{i=1}^{N-k} P(i) \quad (2)$$

$$\mu(N, k) = N/(k + 1) \quad (3)$$

GECCO-2008 -31

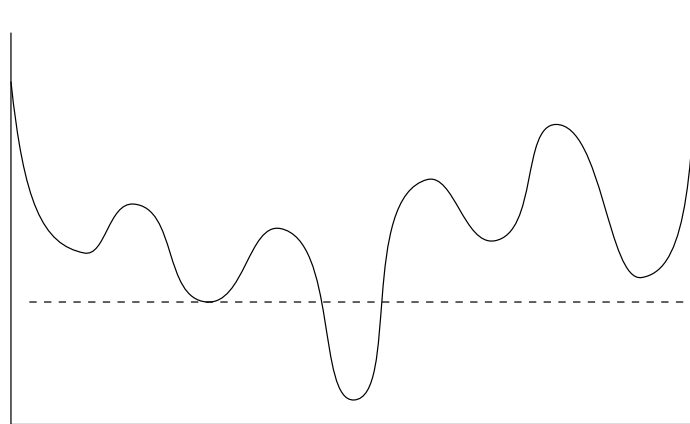

GECCO-2008 -32

GECCO 2008 Tutorial / No Free Lunch

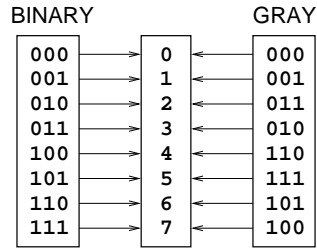

	Gray Matrix	Degray Matrix
3-bits	$\begin{vmatrix} 1 & 1 & 0 \\ 0 & 1 & 1 \\ 0 & 0 & 1 \end{vmatrix}$	$\begin{vmatrix} 1 & 1 & 1 \\ 0 & 1 & 1 \\ 0 & 0 & 1 \end{vmatrix}$
5-bits	$\begin{vmatrix} 1 & 1 & 0 & 0 & 0 \\ 0 & 1 & 1 & 0 & 0 \\ 0 & 0 & 1 & 1 & 0 \\ 0 & 0 & 0 & 1 & 1 \\ 0 & 0 & 0 & 0 & 1 \end{vmatrix}$	$\begin{vmatrix} 1 & 1 & 1 & 1 & 1 \\ 0 & 1 & 1 & 1 & 1 \\ 0 & 0 & 1 & 1 & 1 \\ 0 & 0 & 0 & 1 & 1 \\ 0 & 0 & 0 & 0 & 1 \end{vmatrix}$

GECCO-2008 -33

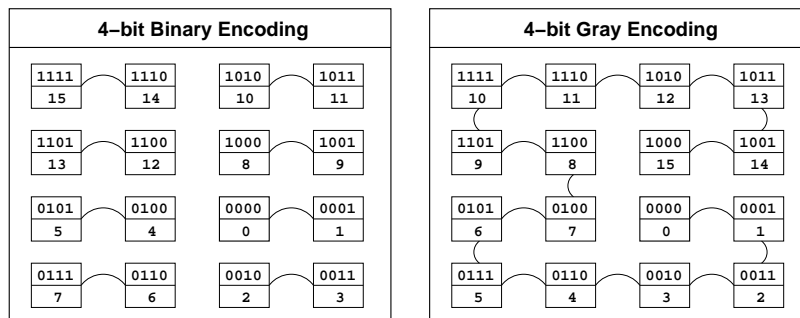

GECCO-2008 -34

GECCO 2008 Tutorial / No Free Lunch

”NO-FREE-LUNCH-like” results hold over very small sets of functions for Gray and Binary representations.

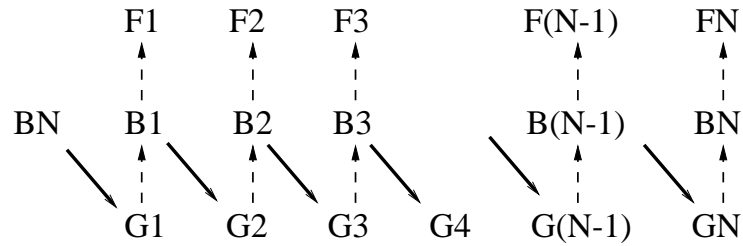

The length of this “chain” is at most $2L$.

GECCO-2008 –35

R1:	000	001	010	011	100	101	110	111
R2:	000	001	011	010	110	111	101	100
R3:	000	001	010	011	101	100	111	110
R4:	000	001	011	010	111	110	100	101
R5:	000	001	010	011	100	101	110	111

GECCO-2008 –36

GECCO 2008 Tutorial / No Free Lunch

Consider the integer-adjacency neighborhood.

1, 2, 3, 4, 5, 6, 7, 8, ... N-3, N-2, N-1, N

We consider a WRAPPING Neighborhood
where 1 and N are neighbors.

(We can also consider a NON-WRAPPED Neighborhood,
where 1 and N are not neighbors).

GECCO-2008 –37

FOR WRAPPING FUNCTIONS			
	#F	# of Min	# of Min
K	K Min	Gray	Binary
1	512	512	1,024
2	14,592	23,040	27,776
3	23,040	49,152	48,896
4	2,176	7,936	2,944
Sum	40,320	80,640	80,640

GECCO-2008 –38

2607

MINI-MAX: WRAPPING			
K	Gray Wins	Binary Wins	Ties
1	448	0	64
2	6752	2288	5552
3	6720	6592	9728
4	0	2160	16
Sum	13,920	11,040	15,360

GECCO-2008 -39

Generating the Set of All Functions

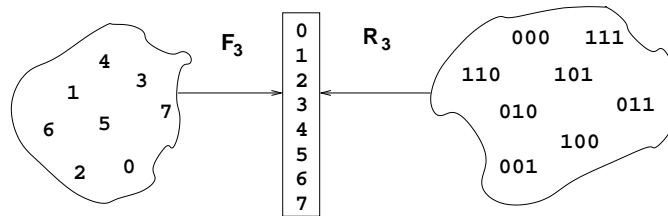

Count the Minima in the Set of All Functions

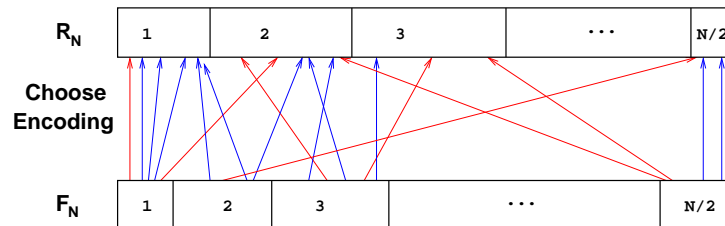

GECCO-2008 -40

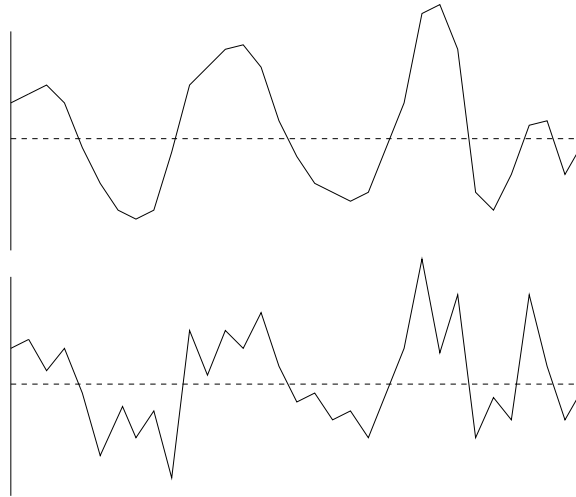

GECCO-2008 -41

A SubThreshold-Seeker

1. Evaluate a sample of points and estimate a $threshold(f)$.
2. Pick point $x < threshold(f)$.
3. If $f(x) < threshold(f)$ then set $x = x + 1$ and $y = x - 1$;
Else sample a new random point.
4. While $f(x) < threshold(f)$ set $x = x + 1$;
5. While $f(y) < threshold(f)$ set $y = y - 1$;
6. If stopping-conditions not met, goto 2.

GECCO-2008 -42

Define a *quasi-basin* as a contiguous set of points below threshold. Let α define a threshold presenting some fraction of the search space. Suppose there are B quasi-basins each containing at least M points.

Theorem: *Suppose that Subthreshold-Seeker is used to find B quasi-basins each containing at least M points. For all $\alpha < 1/2$ subthreshold-seeker beats random search if $M > \sqrt{\frac{NH(B-1)}{B}}$.*

$\sqrt{\frac{NH(B-1)}{B}}$ does not reference α because M is derived from α .

GECCO-2008 -43

What about a simple bit climber using Gray Code?

Theorem: *Given a quasi-basin that spans $1/Q$ of a search space of size N and a reference point R inside the quasi-basin, the expected number of neighbors of R that fall inside the quasi-basin under a reflected Gray code is greater than*

$$\lfloor (\log(N/Q)) \rfloor - 1$$

Corollary: *Given a quasi-basin below threshold α that spans $1/Q$ of the search space and a reference point R that fall in the quasi-basin, the majority of the neighbors of R under a reflected Gray code representation of a search space of size N will also be subthreshold in expectation when*

$$\lfloor (\log(N/Q)) \rfloor - 1 > \log(Q) + 1$$

GECCO-2008 -44

GECCO 2008 Tutorial / No Free Lunch

This means that a simple “local search” bit climber can beat random enumeration when restarted from a subthreshold points as long as on average

$$\lfloor (\log(N/Q)) \rfloor - 1 > \log(Q) + 1$$

Let $N = 2^{100}$ and assume we want to largely sample a quasi-basin that spans $1/\text{billion}^{\text{th}}$ of the space.

$$\lfloor (\log(2^{100}/2^{30})) \rfloor - 1 > \log(2^{30}) + 1$$

$$69 > 31$$

NOTE: An increase in precision increases $\lfloor (\log(N/Q)) \rfloor - 1$ but does not increase $\log(Q) + 1$.

GECCO-2008 -45

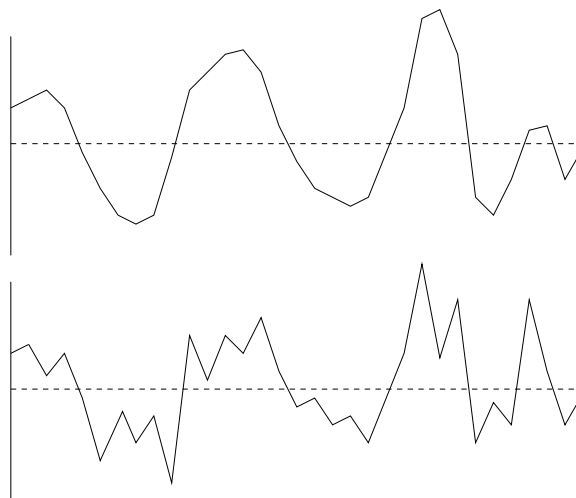

GECCO-2008 -46

GECCO 2008 Tutorial / No Free Lunch

Func	ALG	<i>10 bit Precision</i>			<i>20 bit Precision</i>		
		Mean	Sub	Evals	Mean	Sub	Evals
ackley	R-LS	0.18	62.4	19371	0.0001	75.1	77835
	SubT	0.18	79.7	16214†	0.0001	89.9	73212†
griewangk	R-LS	0.010	59.5	13412	0.0045	80.3	66609
	SubT	0.005	80.1	9692†	0.0049	90.0	59935†
rana	R-LS	-49.6	49.5	22575	-49.76	74.2	3×10^6
	SubT	-49.4	57.6	19453†	-49.83	85.0	3×10^6

Table 1: Local Search Results averaged over 30 runs. Threshold = 10 percent. The † denotes statistical significance.

GECCO-2008 –47

References

- [1] S. Christensen and F. Oppacher. *What can we learn from No Free Lunch*. GECCO 2002.
- [2] J. Culberson. On the Futility of Blind Search. *Evolutionary Computation*, 6(2):109–127, 1999.
- [3] S. Droste and T. Jansen and I. Wegener. Perhaps not a free lunch but at least a free appetizer. *GECCO*, 1999.
- [4] S. Droste and T. Jansen and I. Wegener. Optimization with randomized search heuristics; the (A)NFL theorem, realistic scenarios and difficult functions. *Theoretical Computer Science*, 2002 (In Press).
- [5] T. English. Practical implications of new results in conversation of optimizer performance. *Parallel Problem Solving from Nature*, 2000.
- [6] T. English. Information is Conserved in Optimization. *IEEE Trans Evolutionary Computation*.
- [7] N.J. Radcliffe and P.D. Surry. Fundamental limitations on search algorithms: Evolutionary computing in perspective. *Lecture Notes in Computer Science 1000*. Springer-Verlag, 1995.
- [8] C. Schumacher. *Fundamental Limitations of Search*. PhD thesis, University of Tennessee, Department of Computer Sciences, Knoxville, TN, 2000.
- [9] C. Schumacher and M. Vose and D. Whitley. *The No Free Lunch and Problem Description Length*. GECCO 2001.
- [10] D. Whitley. Functions as permutations: regarding no free lunch, walsh analysis and summary statistics. *Parallel Problem Solving from Nature*, 6, 2000.
- [11] D.H. Wolpert and W.G. Macready. No free lunch theorems for search. Technical Report SFI-TR-95-02-010, Santa Fe Institute, July 1995.
- [12] D.H. Wolpert and W.G. Macready. No free lunch theorems for optimization. *IEEE Trans Evolutionary Computation*, 4:67–82, 1997.

GECCO-2008 –48